

U-Nut

A lightweight, self-retaining nut solution that allows for single tool assembly



High Strength

Achieves performance through the multi-threaded barrel extrusion.



Fastener Standardization

Accommodates a range of panel thicknesses and material types.



Enables Lightweighting

Achieves ~50% weight reduction over a cold formed nut while offering same strength properties.



Direct Push Installation

Allows for tool-free installation. Automation compatible.



Visible Pre-Assembly

Installs and retains in panel prior to final assembly.



**Installs over
Circular Hole**

Ideal Applications:



Instrument Panel

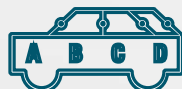

Pillars



Center Console

For more information **contact your Account Manager or call 248.589.2500**

U-Nut



High Strength



Fastener
Standardization



Enables
Lightweighting



Direct Push
Installation



Visible
Pre-Assembly

Hand installs onto panel
before single tool assembly

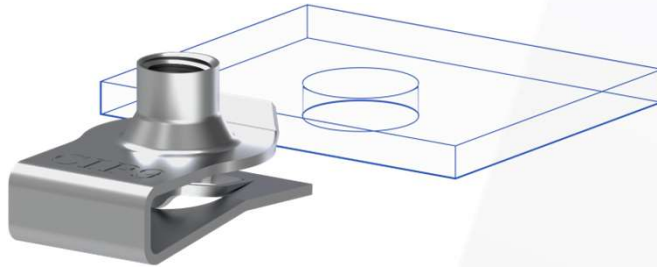

Retains self in panel hole.
Can be removed, reused, and
reassembled multiple times

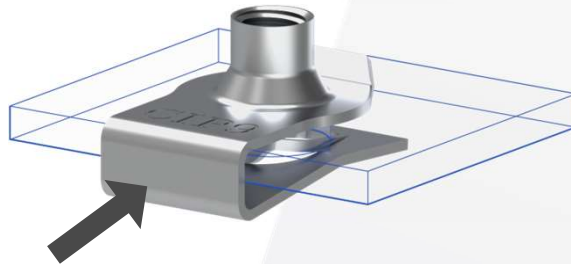

Design prevents over-rotation
during torque-down

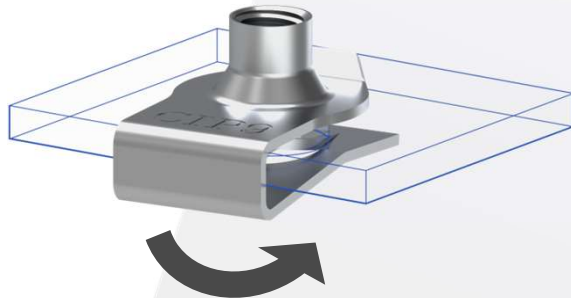

Fully assembled view

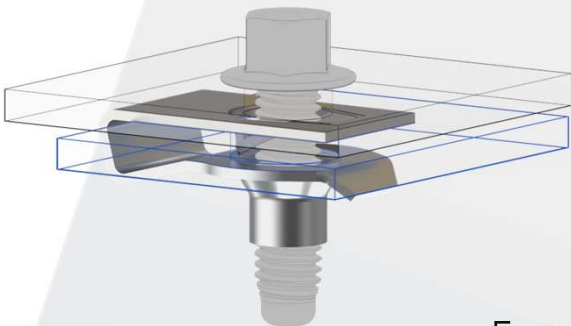

Available in collated stacks
for automated installation

For more information **contact your
Account Manager or call 248.589.2500**