

MidPanel Nut™

A self-retaining nut solution providing high strength performance and allowing for flush and tight joints



High Strength

Achieves performance through the multi-threaded barrel extrusion and excellent retention via expanding legs.



Direct Push Installation

Installs with a single push. Automation compatible.



Enables Lightweighting

Achieves ~50% weight reduction over a cold formed nut while offering same strength properties.



Enables Close Panels

Allows for tight panel fit and flush joints when used in plastic and metal panels with a recessed hole.



Visible Pre-Assembly

Installs and retains in panel prior to final assembly.

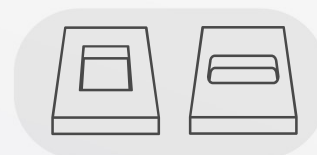

Installs into Recessed Square or Rectangular Hole

Ideal Applications:



Instrument Panel

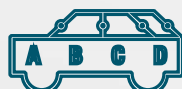

Pillars



Center Console

For more information **contact your Account Manager** or call **248.589.2500**

MidPanel Nut™



High Strength



Direct Push
Installation



Enables
Lightweighting



Enables Close
Panels



Visible
Pre-Assembly

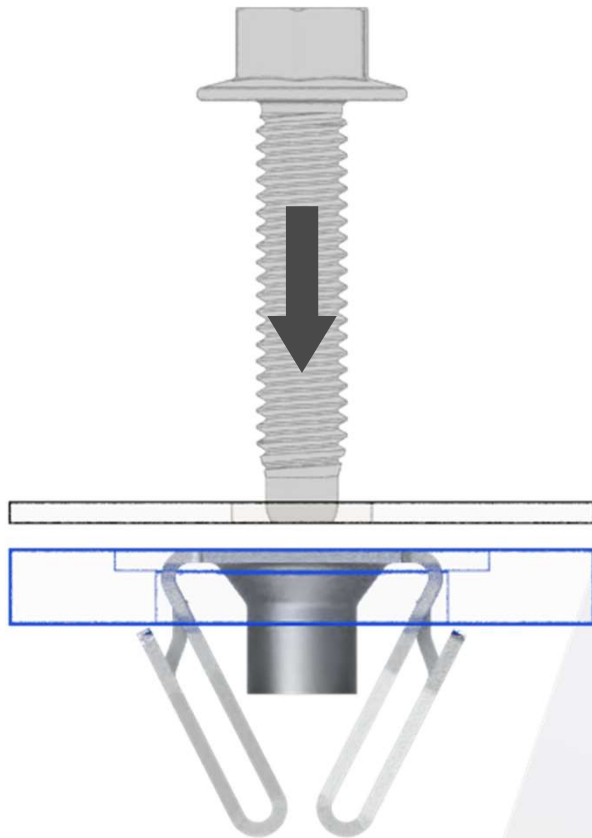

Installs into recessed hole before
final assembly

(Plastic panel type shown above)

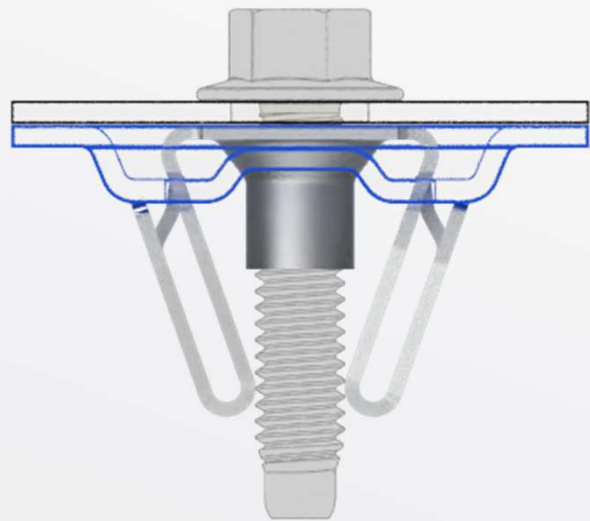

Panels assemble as a flush joint
for a tight fit

(Metal panel type shown above)

For more information **contact your
Account Manager or call 248.589.2500**