

Box Nut

A self-retaining nut solution providing high strength performance, ergonomic friendly installation, and accommodating of a wide panel range



High Strength

Achieves performance through the multi-threaded barrel extrusion and excellent retention via expanding legs.



Ergonomic Installation

Installs with a single push at 45N (10 LBF) MAX. Automation compatible.



Enables Lightweighting

Achieves ~50% weight reduction over a cold formed nut while offering same strength properties.



Fastener Standardization

Accommodates a range of panel thicknesses and material types.



Visible Pre-Assembly

Installs and retains in panel prior to final assembly.

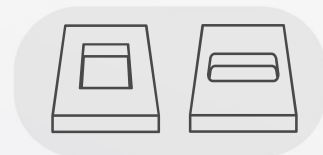

Installs into Square or Rectangular Hole

Ideal Applications:



Instrument Panel



Pillars



Center Console



Door Panel & Mechanism

For more information **contact your Account Manager or call 248.589.2500**

Box Nut



High Strength



Ergonomic Installation



Enables Lightweighting



Fastener Standardization



Visible Pre-Assembly

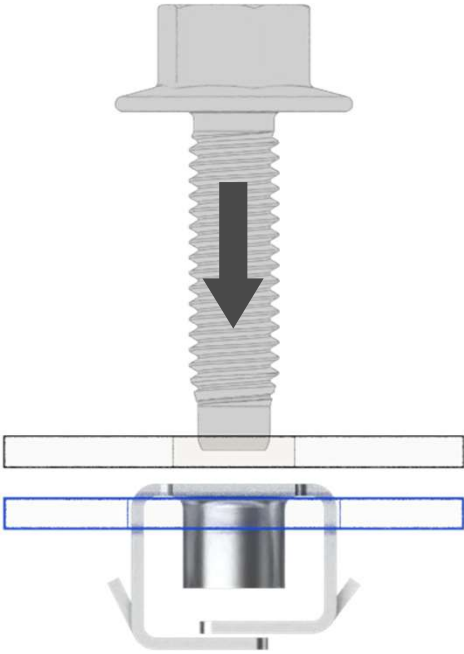

Installs and retains in panel before final assembly

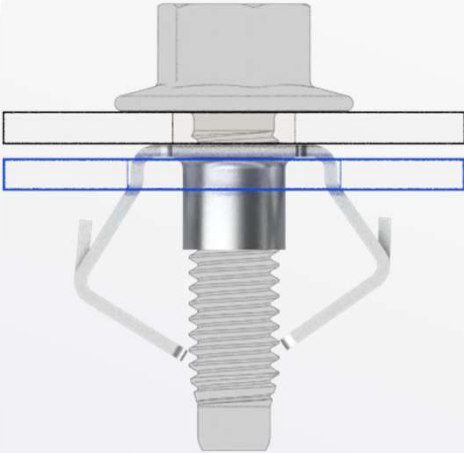

Legs expand during assembly with bolt for high retention



Multiple coating options

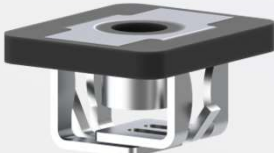

Silicone pad version for NVH and sealing

For more information **contact your Account Manager or call 248.589.2500**